



DTM Distributed Transmitter Monitor

DTM20 Seismic Vibration Distributed Transmitter-Monitor

(Acceleration, Velocity and Displacement)

The DTM20 distributed vibration transmitter-monitor provides a simple and cost-effective solution for monitoring “balance-of-plant” equipment. The DTM20 monitor can interface with almost any seismic vibration sensor and can be fully field-configurable. In addition to this it also improves system reliability with redundant power supplies and redundant 4-20mA transmissions.



Applications include:

- ✓ Motors
- ✓ Pumps
- ✓ Fans
- ✓ Blowers
- ✓ Engines
- ✓ Compressors
- ✓ Centrifuges
- ✓ Generators
- ✓ Turbines
- ✓ Turbochargers

DTM20 Fully Configurable via Software

- ✓ Acceleration Monitor
- ✓ Velocity Monitor
- ✓ Displacement Monitor

DTM20 Features

- ✓ Measures acceleration, velocity or displacement
- ✓ Direct Modbus RTU interface
- ✓ Redundant 4-20mA outputs (pk or RMS)
- ✓ Redundant power supplies
- ✓ Fully digital field-configuration
- ✓ Dual relay output with Alert and Danger (SPDT)
- ✓ LED indication of system OK, alert, and danger
- ✓ Local and remote RESET / BYPASS and trip-multiply
- ✓ Buffered Output for condition monitoring
- ✓ Aluminum case for RF/EMI
- ✓ Epoxy potted for better environmental protection
- ✓ Signal filtering
- ✓ Digital condition monitoring (optional)



DTM Distributed Transmitter Monitor

Specifications

Electrical

Power Supply:

22-30VDC, 150mA.

Accepts dual power supply inputs

Galvanic isolation:

Among power, circuits and alarms

Frequency Response (-3dB):

Nominal Frequency:

Acceleration: 4 ~ 3KHz

Velocity: 4 ~ 3KHz

Displacement: 4 ~ 3KHz

Low Frequency:

Acceleration: 0.5 ~ 100Hz

Velocity: 0.5 ~ 100Hz (TM079VD)

Displacement: 0.5 ~ 100Hz(TM079VD)

High Frequency:

Acceleration: 10 – 20KHz (peak)

Filtering:

8 pole 160dB/ Dec .Low-pass

1 pole 20dB/ Dec. High-pass

Factory setting

Customer specifiable

ICP Sensor Interface:

Sensitivity:

100mV/g

100mV/in/sec

4mV/um

Specified sensitivity of any vibration sensor

Current Source

Nominal 4mA@24VDC

Seismic Velocity Sensor Interface:

Sensitivity:

User specified for any vibration sensor

Software programmable

Buffered Output:

Original vibration, un-filtered

Impedance: 150 Ω

Maximum cable distance: 300m (1000ft)

Sensitivity: same as the sensor

Local BNC connection and remote terminal connection

4-20mA Output:

Dual 4-20mA, sourced (loop power not required)

Maximum load resistance 500 Ω

Alarm Setup: 0 ~ 100% FS

Accuracy: $\pm 0.1\%$.

Relays:

Seal: Epoxy.

Capacity: 0.2A/240VAC,

0.4A/110VAC

2.0A/24VDC, resistive load

Relay type: SPTD

Isolation: 1000VDC

LED Machine Condition Indicator:

OK: System OK indication

ALT: Vibration over Alert level

DNG: Vibration over Danger level

BYP: System in BYPASS

TRX: Digital transmission active

RESET/BYPASS:

Front panel push-button

Remote RESET/BYPASS terminals

Trip-Multiply

Double Multiply or Triple Multiply set in DTM-CFG

Short Trip/Multi terminal to COM terminal

System alarm level will increase by a factor of 2 or 3

Modbus:

RS485 Modbus RTU

Non-isolated (use DTM96 for isolation)

Software programming (DTM-CFG):

Alert and danger set-point, time delay

ZERO and Full-Scale calibration

Full-scale high and low setup

Alarm latching/ non-latching, energized/ de-energized

Alarms programmable with alert, danger or system ok

Sensor selection and system calibration

Measurand / Integration changes: A, V, D

Modbus communication setup

Trip-multiply setup



DTM Distributed Transmitter Monitor

Electrical specifications continued

- Real-time bar-graph and alarms
- 3 layers of password protection

Digital condition monitoring (optional)

Condition management software or portable vibration data collector of ProvibTech could collect, store, and analyze machine health condition based on vibration via the bus communication of the DTM20.

Dynamic waveform data:

Real-time vibration data could be uploaded and the waveform and spectrum plot could be view by Condition management software or portable vibration data collector.

Trend Data:

The vibration data could be periodically stored by the DTM20 when it's powered on. User could collect trend data and view trend plots by Condition management software or portable vibration data collector. The trend sampling interval is configured by the related DTM-CFG software. DTM20's factory default is 10 hours. Every DTM20 could store maximum 1024 trend data.

Alarm Data:

The dynamic alarm data could be stored by the DTM20 when it's powered on. The DTM20 only stores one alarm data with highest measured value. User could view waveform and spectrum plot of alarm data by Condition management software or portable vibration data collector.

Physical

Dimension:

Height: 75mm (2.95")
see figure below

Weight: 2.0lb (1.0kg)

Case: Aluminum cast (copper free)

Environmental

Temperature:

Operation: -40°C ~ +85°C.

Storage: -50°C ~ +100°C.

Humidity: 90% non-condensing.

Certification

CE certified with EMI compliance

CSA: Class I, Div. 2, Grps A,B,C&D,T4

ATEX: II 3G Ex nA II T4

GOST R: 2Ex nA II T4X

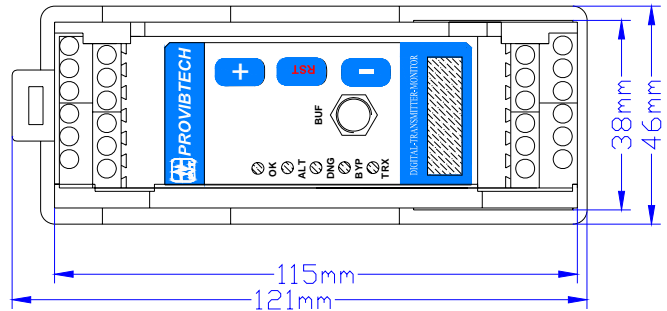

Rail Mounting

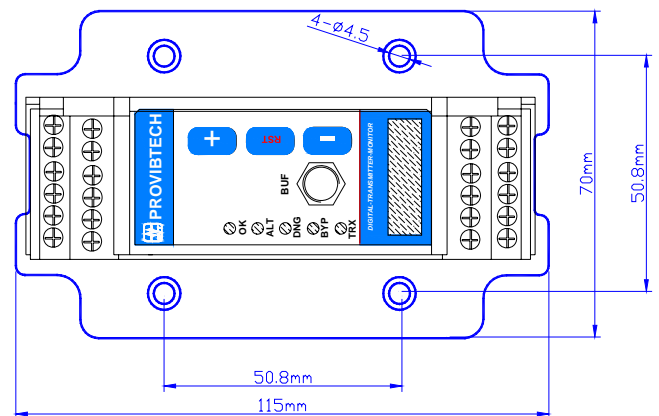

Plate Mounting



DTM Distributed Transmitter Monitor

Ordering Information

DTM20-AX-BX-IX-MX-SX

Customer configurable seismic distributed transmitter-monitor

Distributed vibration monitor, fully field configurable, with Modbus RTU.

AX: Alarm and sensors

- A0: With Epoxy sealed relays, ICP sensors
- A1: No Alarm, ICP sensors
- A2: Dual epoxy sealed relay alarms, seismic velocity
- A3: No Alarm, seismic velocity

BX: Mounting

- B0: DIN rail mounting.
- B1: Plate mounting.

IX: Frequency response

- I0*: Normal/ High frequency
- I1: Low frequency

MX: Digital Communication

- M1*: With Modbus
- M2: With Modbus and digital condition monitoring

SX: Approvals

- S0*: CE
- S1: CE
- CSA: Class I, Div. 2, Grps A,B,C&D,T4
- ATEX: II 3G ExnA II T4
- GOST R: 2Ex nA II T4X

DTM20-101-AXX-CX-GX-HX-IX-MX-SX

Factory configured seismic monitor

AXX: Full Scale

- A00: 0 - 200um pk-pk
- A01: 0 - 500um pk-pk
- A02: 0 - 100um pk-pk
- A03: 0 - 250um pk-pk
- A05: 0 - 125um pk-pk
- A06*: 0 - 50mm/s pk
- A07: 0 - 100mm/s pk
- A08: 0 - 20mm/s pk
- A11: 0 - 25mm/s pk
- A12: 0 - 5.0g pk
- A13: 0 - 10g pk

- A14: 0 - 8mil pk-pk
- A15: 0 - 20mil pk-pk
- A16: 0 - 4mil pk-pk
- A17: 0 - 10mil pk-pk
- A18: 0 - 5mil pk-pk
- A19: 0 - 2.0 ips pk
- A20: 0 - 4.0 ips pk
- A21: 0 - 0.8 ips pk
- A22: 0 - 1.0 ips pk
- A26: 0 - 50mm/s rms
- A27: 0 - 100mm/s rms
- A28: 0 - 20mm/s rms
- A31: 0 - 25 mm/s rms
- A32: 0 - 2.0 ips rms
- A33: 0 - 4.0 ips rms
- A34: 0 - 0.8 ips rms
- A35: 0 - 1.0 ips rms

CX: Alarms

- C0*: Dual alarms with epoxy sealed relays
- C1: No Alarm

GX: Mounting

- G0*: DIN rail mounting.
- G1: Plate mounting.

HX: Sensor (not include)

- H0*: TM0782A or any ICP accelerometer with 100mV/g (A00~A05 not available)
- H1: TM0793V or any ICP velocity sensor with 4mV/mm/s (A12, 13 not applicable)
- H2: TM079VD (A12, 13 not available)
- HXXX: Seismic velocity sensor, Sensitivity = XXX mV/in/sec (A12, 13 not available)

IX: Frequency Response

- I0*: Normal Frequency (4 ~ 3KHz, H2 not available)
- I1: Low Frequency (0.5~100Hz)
- I2: High frequency (10 - 20KHz, A12, A13 only with accelerometer)

MX: Digital Communication

- M1*: With Modbus
- M2: With Modbus and digital condition monitoring

SX: Approvals

- S0*: CE
- S1: CE
- CSA: Class I, Div. 2, Grps A,B,C&D,T4
- ATEX: II 3G ExnA II T4
- GOST R: 2ExnAII T4X

* Denotes factory default.



DTM Distributed Transmitter Monitor

Optional Accessories

DTM-CFG-K

The DTM configuration and calibration software kit includes:

- ✓ DTM-CFG configuration and calibration software CD
- ✓ RS485-USB converter with cable

Seismic Sensor Systems

- ✓ **TM0782A-K-M:** Accelerometer kit
- ✓ **TM0783A-K-M:** Accelerometer with cable
- ✓ **TM0793V-K-M:** Velocity sensor kit
- ✓ **TM079VD-V/H-K:** Low frequency sensor

TM900

Power converter with isolation. Converts 95-250 VAC into 24VDC and is capable of powering up to five DTM modules.



DTM Distributed Transmitter Monitor

DTM20 System Installation

DTM20 Field-Wiring Diagram

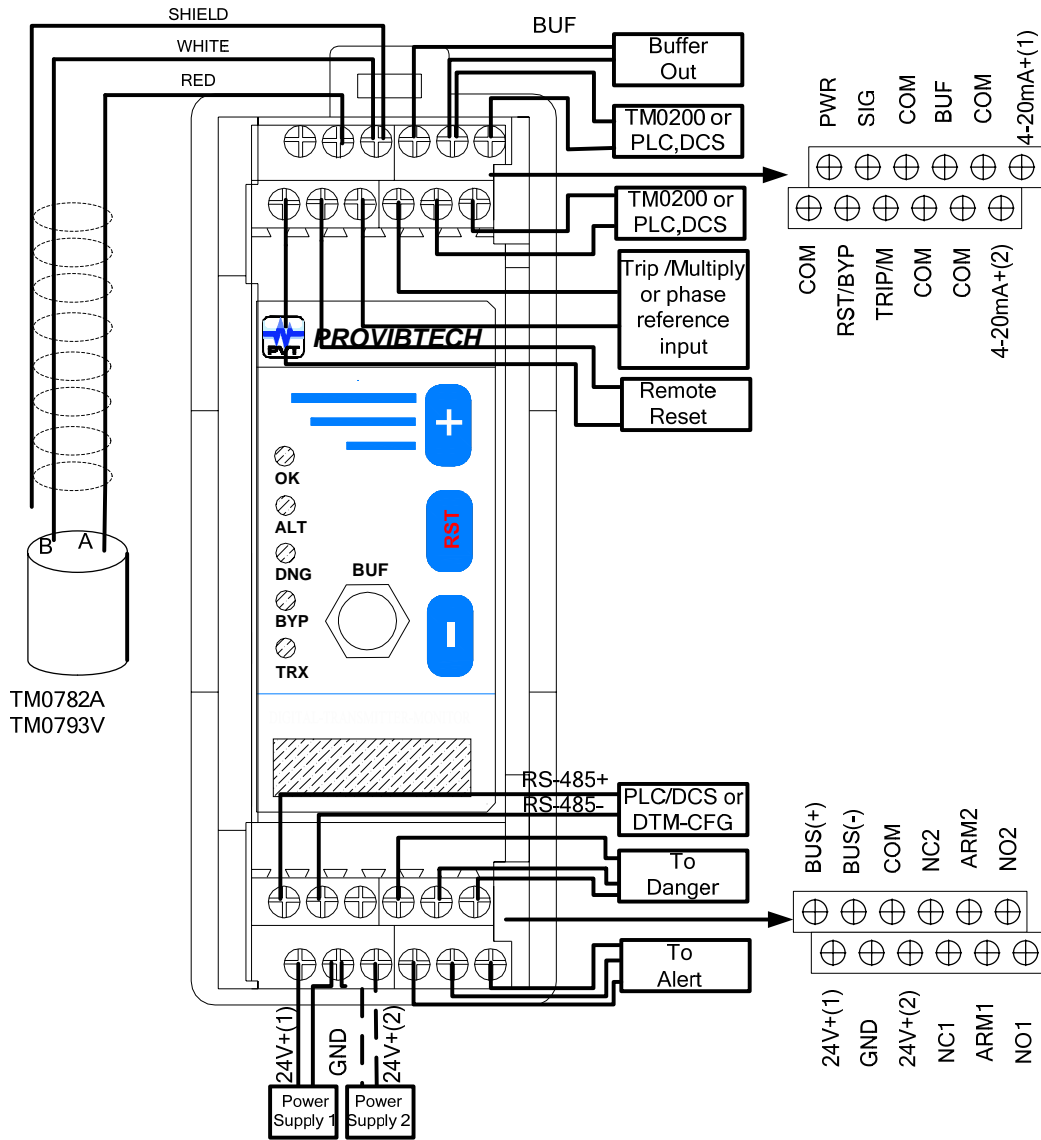

Note:

- ✓ Power supply 2 and 4-20mA(2) are optional connections used for redundancy.
- ✓ Alert and Danger relays are shown connected as normally open. Connect ARM and NC for normally closed.
- ✓ Connecting COM and RST/BYP with an external continuous or momentary closed switch will initiate a remote reset. Temporarily closing the switch will result in a system reset, continuous close will result in a system bypass.
- ✓ If DTM20 has the digital condition monitoring function, the Trip/Multi and COM pins are used for phase reference input. Thus, the DTM20 won't provide the Trip Multiply and the Trip Multiply property should be set to "None" in the DTM-CFG software.
- ✓ When using the signal condition monitoring function the DTM20 works with DTM10-501/502 to provide a phase reference output. In this case connect Trip/Multi of DTM20 with Trip/Multi of DTM10-501/502 and connect COM of DTM20 with COM of DTM10-501/502.



DTM Distributed Transmitter Monitor

DTM20 Hazardous Area Field-Wiring Diagram

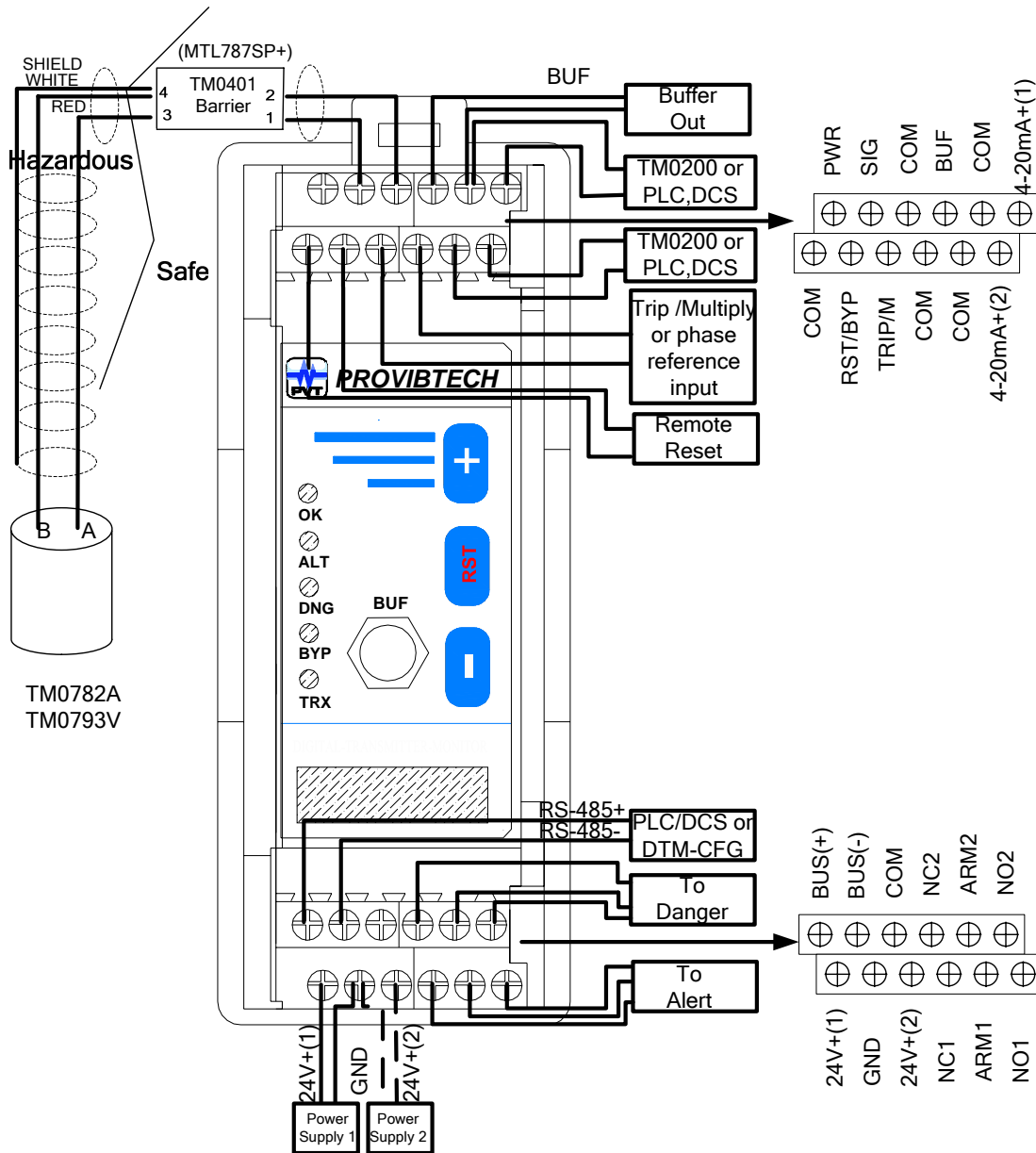

Note:

- ✓ Power supply 2 and 4-20mA(2) are optional connections used for redundancy.
- ✓ Alert and Danger relays are shown connected as normally open. Connect ARM and NC for normally closed.
- ✓ Connecting COM and RST/BYP with an external continuous or momentary closed switch will initiate a remote reset. Temporarily closing the switch will result in a system reset, continuous close will result in a system bypass.
- ✓ If DTM20 has the digital condition monitoring function, the Trip/Multi and COM pins are used for phase reference input. Thus, the DTM20 won't provide the Trip Multiply and the Trip Multiply property should be set to "None" in the DTM-CFG software.
- ✓ When using the signal condition monitoring function the DTM20 works with DTM10-501/502 to provide a phase reference output. In this case connect Trip/Multi of DTM20 with Trip/Multi of DTM10-501/502 and connect COM of DTM20 with COM of DTM10-501/502.