



ProvibTech
Innovative Machine Monitoring

DM200 Dual-Channel A/V/D Vibration Monitor



ProvibTech, Inc. 11011 Brooklet Drive, Suite 300, Houston, Texas 77099, USA

Phone: +1-713-830-7601, Fax: +1-281-754-4972, Email: pvt@provibtech.com, Web: www.provibtech.com



DM200 Dual-Channel A/V/D Vibration Monitor

Introduction

The purpose of the DM200 Dual Vibration Monitor is to measure the vibration levels of rotating machinery in order to ascertain that machines condition or health. The DM200 provides absolute seismic vibration readings in acceleration, velocity, or displacement. This allows the user to detect occurring or developing problems due to machinery imbalance, misalignment, looseness, rolling-element bearing failure, gear defects, etc.

Machine Type

- ✓ Any type of machinery including, but not limited to, fans, compressors, electric motors, pumps, gearboxes, and power generators.

Sensor Installation

- ✓ Only need to mill a flat base of 30mm in diameter, and drill a M6 hole in the middle to install the sensor. No need to do anything inside the machine.

Output terminal

- ✓ Each channel has a 4-20mA output.
- ✓ Each channel has two separate SPDT output (6 output terminal "ALERT" and "DANGER").
- ✓ Remote RESET/BYPASS ("RESET" and "COM"). Short RESET and COM will engage system reset and bypass.
- ✓ TRIP/MLTP. Short Trip/Multi and COM, then set Double Multiply or Triple Multiply by software, system alarm value will increase a factor of 2 or 3.
- ✓ Buffered / Dynamic output for each channel.
- ✓ Front Panel LED indications of current vibration level, OK status, and alert / danger status.
- ✓ Available in all hazardous Area (Used with TM0401).
- ✓ MODBUS output for communication with upper-level controller such as PLCs or DCSs.



Specifications

Electrical

Power Supply:

90-250VAC, 40-60Hz, 50mA

Frequency Response: ($\pm 3\text{dB}$):

Standard: 2.0 – 3.0 KHz without integration;

Integration: 10 – 3.0 KHz;

Low frequency option: 0.5 – 100Hz.

External Sensor:

Sensitivity: 100mV/g for accelerometer;

4.0mV/mm/s for velocity sensor;

40mV/mm/s or 4.0mV/ μm for low frequency velocity/displacement sensor.

External ICP sensor:

24VDC, 4mA

Connectors: "P/A": with red;

"S/B": with white.

External low frequency sensor:

"P/A": with red;

"S/B": with white.

Buffered Output:

Original vibration, un-filtered;

Sensitivity/frequency: same as the sensor specification.

Impedance :550 Ω ;

Maximum cable distance: 300m (1000ft).

Overall Vibration:

4-20mA source driving load resistance up to 500 Ω .

System OK: Each channel output 4-20mA;

System Not OK: Output < 3.5mA.



DM200 Dual-Channel A/V/D Vibration Monitor

Two Level Alarm:

Alarm setup (Normal/Set):

Scale: 0-100%full scale;

Accuracy: $\pm 0.1\%$.

Relays (Alert/Danger):

Seal: Epoxy.

Capacity: 3A/220VAC or 3A/24VDC
resistive load.

Relay Type: SPDT.

Isolation: 1000VDC

Alarm delay:

0-60 seconds.

With time interval of 1 second.

Alarm Multiply:

Short Trip/Multi and COM, then set Double Multiply or Triple Multiply by software, system alarm value will increase a factor of 2 or 3.

RESET/BYPASS:

Local RESET;

Remote RESET/BYPASS: Short REST/BYP and COM

LED Machine Condition Indicator:

CH1 (Green) light on: Display the value of CH1;

CH2 (Green) light on: Display the value of CH2;

OK (Green) light on: Self-test passed, System works OK;

ALARM (red) light on: Alarm indication.

Bus Communication (TX/RX):

All setup and condition parameters can be obtained from the bus connector.

Digital condition monitoring (optional):

Condition management software or portable vibration data collector of ProvibTech could collect, store, and analyze machine health condition based on vibration via the bus communication of the DM200.

Dynamic waveform data:

Real-time vibration data could be uploaded and the waveform and spectrum plot could be view by Condition management software or portable vibration data collector.

Trend Data:

The vibration data could be periodically stored by the DM200 when it's powered on. User could collect trend data and view trend plots by Condition management software or portable vibration data collector. The trend sampling interval is configured by the related DM200-CFG software. DM200's factory default is 10 hours. Each DM200 could store maximum 1024 trend data.

Alarm Data:

The dynamic alarm data could be stored by the DM200 when it's powered on. The DM200 only stores one alarm data with highest measured value. User could view waveform and spectrum plot of alarm data by Condition management software or portable vibration data collector.

Physical

Size: 170*90*120mm (6.69*3.54*4.72inch)

Others as per drawing below:

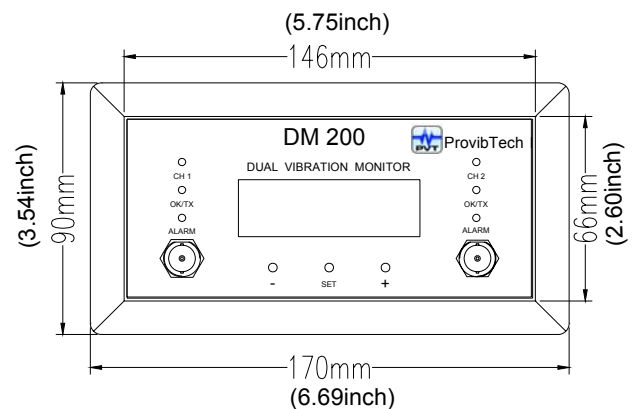

Front View

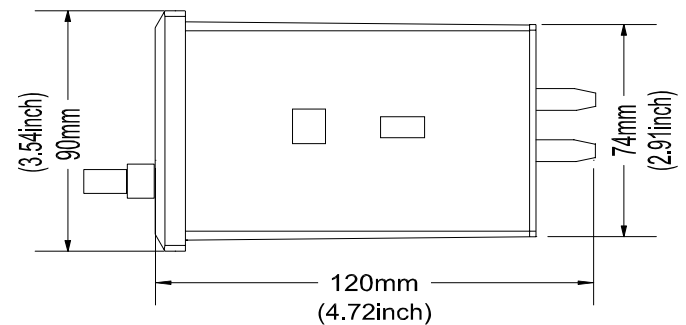

Side View

Weight:

1300 g.

Installation:

With specific Holder.

Environmental

Temperature:

Operation: $-35^{\circ}\text{C} \sim +70^{\circ}\text{C}$;

Storage: $-40^{\circ}\text{C} \sim +100^{\circ}\text{C}$.

Humidity: 95%non-condensing.



Ordering Information

DM200-AXX-BX-CX-DX-EX

AXX: Full Scale

- A12: 0 ~ 5.0g pk
- A13: 0 ~ 10g pk
- A40*: 0 ~ 20mm/s rms
- A41: 0 ~ 25 mm/s rms
- A42: 0 ~ 50mm/s rms
- A43: 0 ~ 100mm/s rms
- A46: 0 ~ 1.0 ips rms
- A47: 0 ~ 2.0 ips rms
- A48: 0 ~ 4.0 ips rms
- A50: 0 ~ 20mm/s pk
- A51: 0 ~ 25 mm/s pk
- A52: 0 ~ 50mm/s pk
- A53: 0 ~ 100mm/s pk
- A56: 0 ~ 1.0 ips pk
- A57: 0 ~ 2.0 ips pk
- A58: 0 ~ 4.0 ips pk
- A60: 0 ~ 100um pk-pk
- A61: 0 ~ 125um pk-pk
- A62: 0 ~ 200um pk-pk
- A63: 0 ~ 250um pk-pk
- A64: 0 ~ 500um pk-pk
- A66: 0 ~ 5mil pk-pk
- A67: 0 ~ 10mil pk-pk
- A68: 0 ~ 20mil pk-pk

BX: Sensor (not include)

- B0*: TM0782A, TM0783A, TM0785A or any ICP accelerometer with 100mV/g (A60-A68 not applicable)
- B1: TM0793V or any ICP velocity sensor with 4mV/mm/s (A12, 13 not applicable)
- B2: TM079VD (A12, 13 not available)
- BXXX: Seismic sensor, Sensitivity = XXX

CX: Frequency Response

- C0*: Normal Frequency (B2 not applicable)
- C1: Low Frequency (B2 only)

DX: Environmental Rating (front panel)

- D0*: No rating
- D1: IP65 or NEMA 4X (buffered output and setting not available)

EX: Digital Communication

- E0*: No digital communication
- E1: With Modbus
- E2: With Modbus and digital condition monitoring

* Factory default

DM200 Accessory

DM200-CFG-K

DM200 configuration and calibration software kit includes:

- ✓ DM200-CFG configuration and calibration software CD
- ✓ RS485-USB converter with cable

Sensors

- TM0782A-K-M:** Accelerometer kit.
- TM0783A-K-M:** Accelerometer with integral cable.
- TM0795A-K-M:** Hi-Temperature Accelerometer kit
- TM0793V-K-M:** Velocity sensor kit.
- TM079VD-V/H-K:** Low frequency velocity/displacement sensor.

TM0303: NEMA housing.

TM0401: barrier.



DM200 Dual-Channel A/V/D Vibration Monitor

DM200 Field-wiring Diagram for TM0782A, TM0793V, TM079VD or other ICP sensor

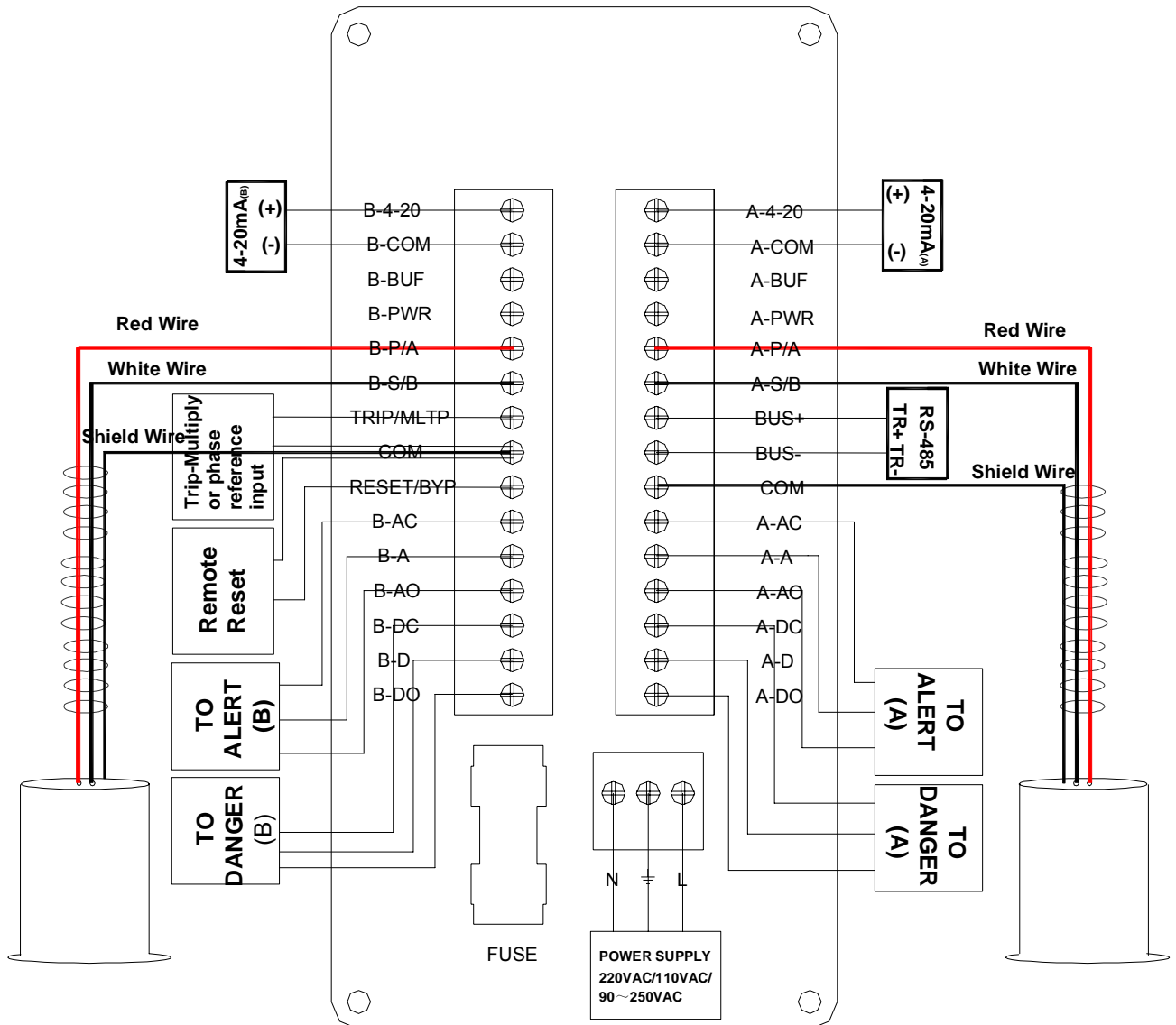

DM200 Nonhazardous Area



DM200 Dual-Channel A/V/D Vibration Monitor

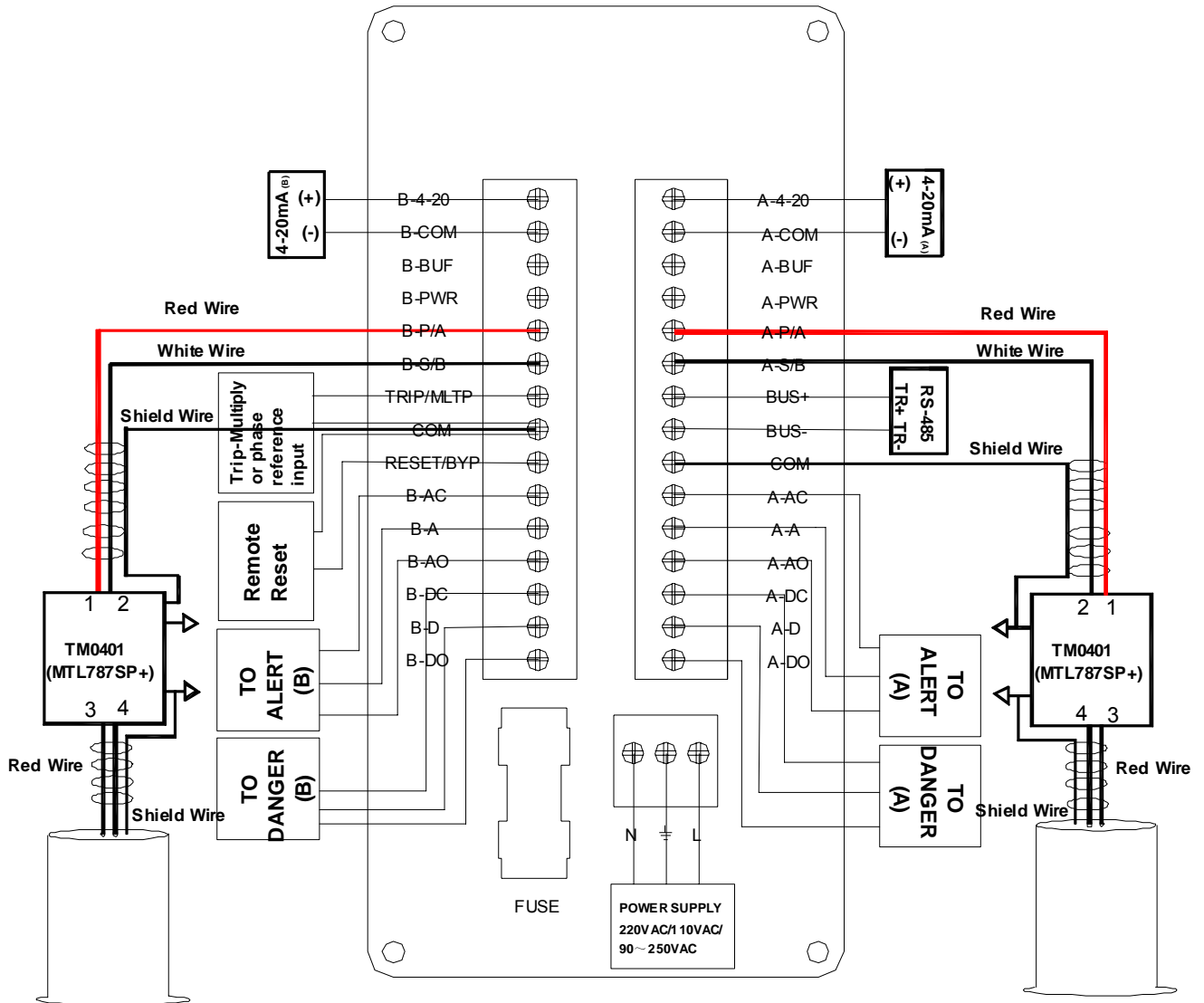

DM200 Hazardous Area

Note:

- ✓ If the DM200 has the digital condition monitoring function, the Trip/Multi and COM pins are used for phase reference input. Moreover, the DM200 won't provide Multiply Alarm function anymore, so you should set Multiply Alarm property to "None" by DM200-CFG software.